

# ITF8802

## MULTI-ADJUSTABLE BENCH

### OWNER'S MANUAL

---

25F

**CAUTION!** Read all precautions and instructions in this manual before using this equipment.

# Table Of Contents

## CAUTION!

Read all precautions and instructions in this manual before using this equipment.

Important Safety Instructions-----	3
Instructions-----	5
Exploded View and Parts List-----	6
Measurement Guide-----	13
Assembly Instructions-----	14
Assembly-----	15
Adjust Instructions and Exercise Instructions-----	19
Maintenance Schedule-----	20
General Maintenance Information-----	21
Weight Training Tips-----	22

---

# Important Safety Instructions

Before beginning any fitness program, you should obtain a complete physical examination from your physician. When using exercise equipment, basic precautions should always be taken, including the following:

1. Read all instructions before using the equipment.  
These instructions are written to ensure your safety and to protect the unit.
2. Use the equipment only for its intended purpose as described in this guide.  
Do not use accessory attachments that are not recommended by the manufacturer: such attachments might cause injuries.
3. The product should only be used on a level surface and is with 0.6 meters space around the product.  
Do not use the equipment outdoors.
4. Do not allow children on or near the equipment. And children are not allowed to use this equipment.  
Teenagers should use this equipment with adult supervision.
5. Do not overexert yourself or work to exhaustion.  
Do not attempt to lift more weight than you can control safely.  
If you feel any pain or abnormal symptoms, stop your workout immediately and consult your physician.
6. This equipment is not used as medical apparatus and instruments.
7. Never operate the unit when it has been dropped or damaged.  
Never drop or insert anything into any opening in the equipment.  
Always check the unit and its cables before each use. Make sure that all fasteners and cables are secure and in good working condition.  
Frayed or worn cables can be dangerous and may cause injury. Periodically check these cables for any indication of wear.  
Keep hands, limbs, loose clothing and long hair well out of the way of moving parts.
8. Be careful when getting on or off the equipment.
9. Wear proper exercise clothing and shoes for your workout, no loose clothing.

# Important Safety Instructions

## Personal Safety During Assembly

Read each step in the assembly instructions and follow the steps in sequence. Do not skip ahead. If you skip ahead, you may learn later that you have to disassemble components and that you may have damaged the equipment.

Assemble and operate the equipment on a solid, level surface. Locate the unit a few feet from walls or furniture to provide easy access. The equipment is designed for your enjoyment. By following these precautions and using common sense, you will have many safe and pleasurable hours of healthful exercise with the equipment.

## Training Area and Free Area

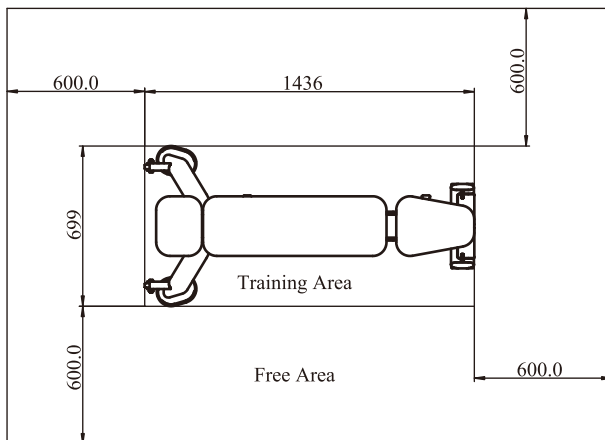

## Specifications

Class: S

Maximum User Weight: 150kg/ 330lbs

Maximum Training Load: 150kg/ 330lbs

Product Dimension: 1436\*699\*430mm

Product Total Surface: 1436\*699mm

Product Total Mass:

# Instructions

Before beginning assembly please take the time to read instructions thoroughly. Please use the various lists in this manual to make sure that all parts have been included in your shipment. When ordering, use part number and description from the lists. Use only our replacement part when servicing. Failure to do so will void your warranty and could result in personal injury.

The equipment is designed to provide the smoothest, most effective exercise motion possible. After assembly, you should check all functions to ensure correct operation. If you experience problems, first recheck the assembly instructions to locate any possible errors made during assembly. If you are unable to correct the problem, call your authorized dealer. Be sure to have your serial number and this manual when calling. When all parts have been accounted for, continue on.

## Tools Required



Ratchet Wrench and Socket



Adjustable Wrench



Rubber Mallet

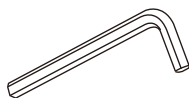

Hex Key Wrench Set



Phillips Screwdriver

# Exploded View and Parts List

## Overall

Grade No.	Part No.	Description	QTY
1	ITF880201ASSY	Underframe ASSY	1
2	ITF880202ASSY	Sleeve Frame I ASSY	1
3	ITF880203ASSY	Back Support Frame ASSY	1
4	ITF880204ASSY	Adjustable Frame I ASSY	1
5	ITF880205ASSY	Sleeve Frame II ASSY	1
6	ITF880206ASSY	Seat Cushion Frame ASSY	1
7	ITF880207ASSY	Adjustable Frame II ASSY	1
8	ITF880208ASSY	Support Frame ASSY	1
9	IT70110900	Shaft	1
10	ITF88023200	Plastic Connection II	1
11	ITF88025100	Back Cushion	1
12	ITF81025100	Head Cushion	1
13	ITF81025200	Seat Cushion	1
14	GB70BTM10*35DN18	Socket Head Cap Screw M10*35	10
15	GB70BTM12*30DN18	Socket Head Cap Screw M12*30	2
16	GB70BTM12*115DN18	Socket Head Cap Screw M12*115	2
17	GB70BTM12*140DN18	Socket Head Cap Screw M12*140	2
18	GB70BTM12*160DN18	Socket Head Cap Screw M12*160	1
19	GB9510DN2	Flat Washer $\Phi 11 * \Phi 20 * 2$	8
20	GB9512DN2	Flat Washer $\Phi 13 * \Phi 24 * 2.5$	12
21	NM12DN2	Nylon Lock Nut M12	5
22	GB9310N19	Spring Washer $\Phi 10$	8
23	GB9312N19	Spring Washer $\Phi 12$	2
24	NBS6DHS	Hex Key S=6	1
25	NBS8DHS	Hex Key S=8	1

# Exploded View and Parts List

## Overall

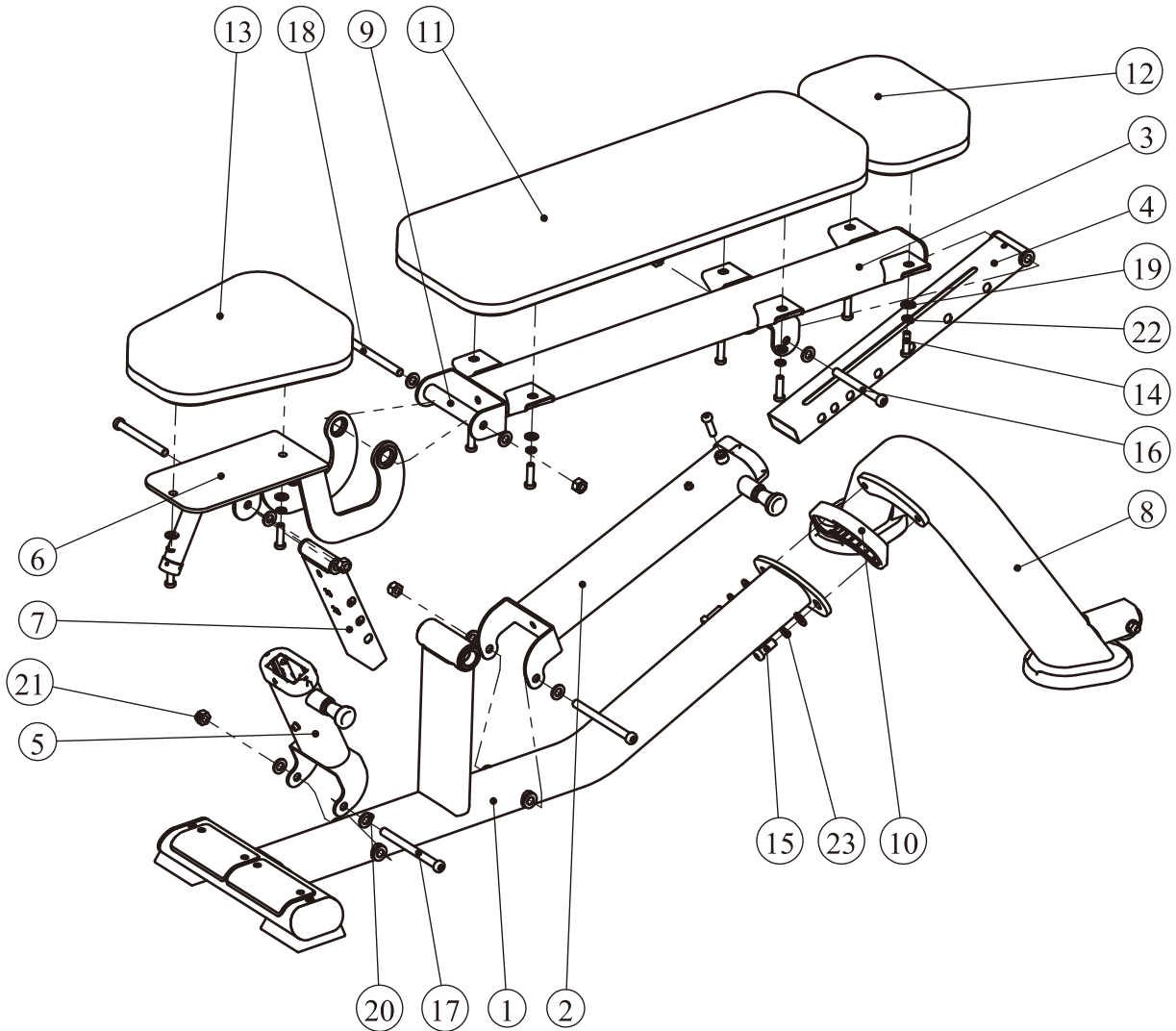

# Exploded View and Parts List

## Underframe ASSY

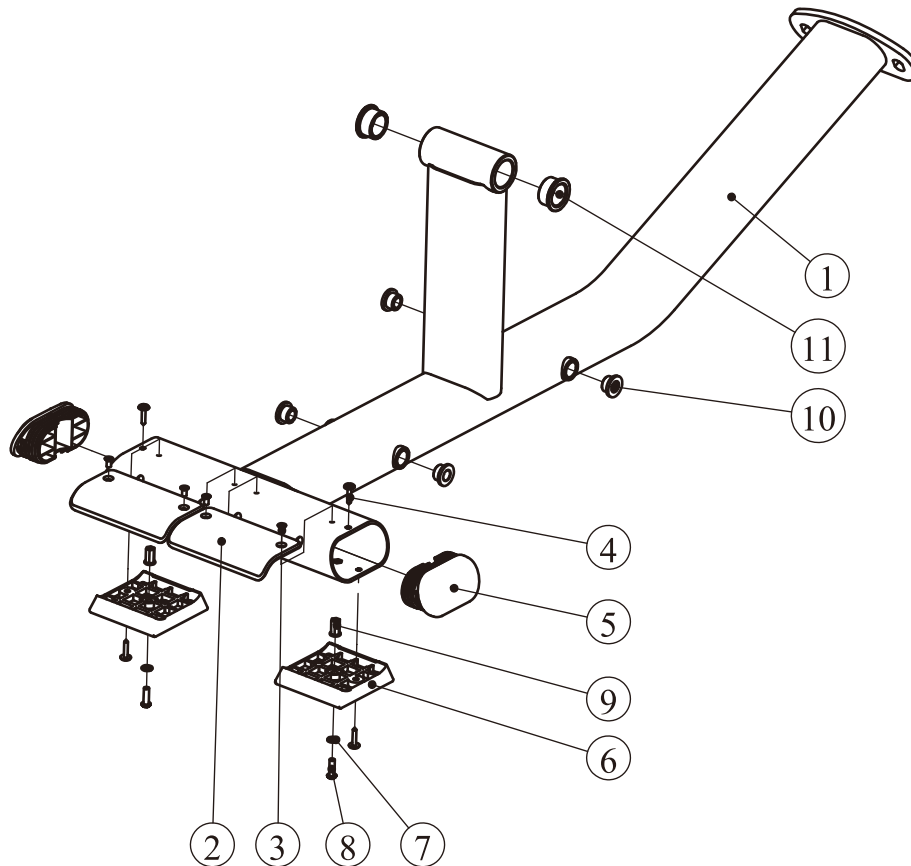

Grade No.	Part No.	Description	QTY
1.1	ITF88020100	Underframe	1
1.2	PS300F10100V1	Ground Shield	2
1.3	GB819M5*10DHS2NL	Phillips Countersunk Screw	4
1.4	GB9074ST4.2*22DHS	Cross Recessed Large Pan Head Tapping Screw	4
1.5	ITF88013100	Pipe Plug	2
1.6	ITF88023100	Floor Mat	2
1.7	GB956DHS2	Flat Washer $\Phi 6.6 * \Phi 12 * 1.6$	2
1.8	PNLM6*20DHS20NL	Button Head Cap Screw M6*20	2
1.9	GB17880.5M6*16.5DS17	Hexagon Rivet Nuts With Flat Head M6*16.5	2
1.10	M01402000	Copper Bearing	4
1.11	M02502000	Copper Bearing	2

# Exploded View and Parts List

## Sleeve Frame I ASSY

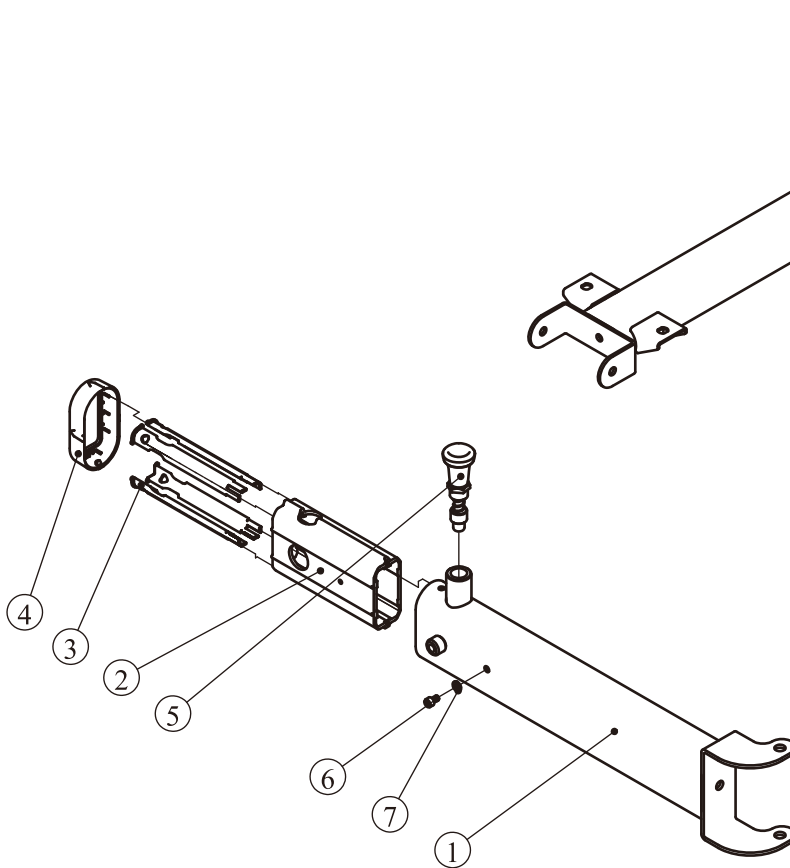

## Back Support Frame ASSY

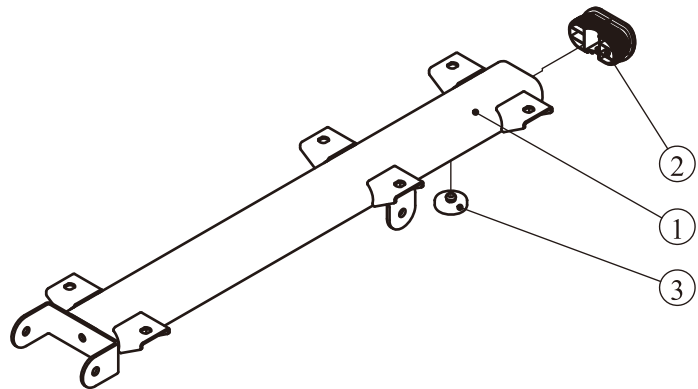

Grade No.	Part No.	Description	QTY
2.1	ITF88020200	Sleeve Frame I	1
2.2	IT95014300V3	Aluminum Tube Guide	1
2.3	IT95016300	Plastic Corner Tube Glide	4
2.4	IT95016200	Plastic Tube Plug	1
2.5	ITF880209ASSY	Plug Pin ASSY	1
2.6	GB70M6*10N19	Socket Head Cap Screw M6*10	1
2.7	GB956DN2	Flat Washer $\Phi 6.6 * \Phi 12 * 1.6$	1

Grade No.	Part No.	Description	QTY
3.1	ITF88020300	Back Support Frame	1
3.2	ITF88013100	Pipe Plug	1
3.3	TLP-2002100	Cushion	1

# Exploded View and Parts List

## Adjustable Frame I ASSY

## Sleeve Frame II ASSY

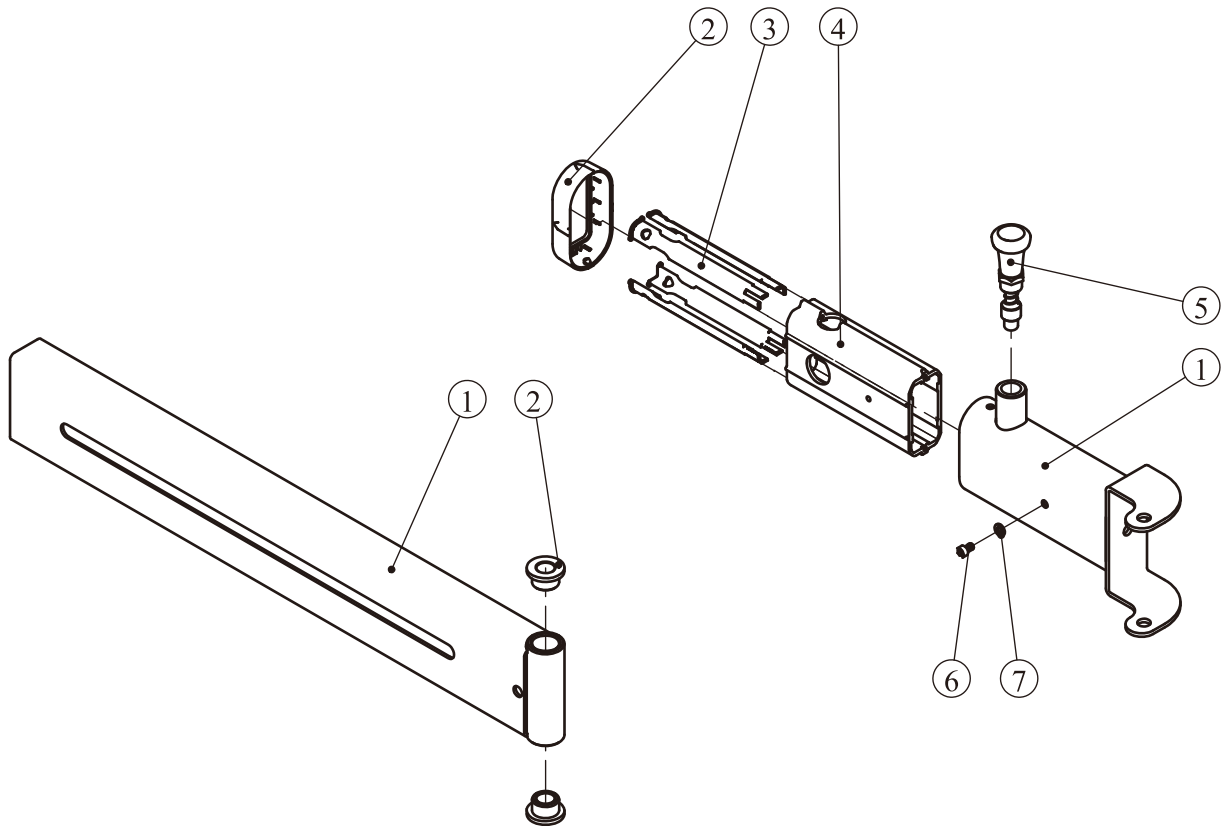

Grade No.	Part No.	Description	QTY
4.1	ITF88020400	Adjustable Frame I	1
4.2	M01402000	Copper Bearing	2

Grade No.	Part No.	Description	QTY
5.1	ITF88020500	Sleeve Frame II	1
5.2	IT95016200	Plastic Tube Plug	1
5.3	IT95016300	Plastic Corner Tube Glide	4
5.4	IT95014300V3	Aluminum Tube Guide	1
5.5	ITF880209ASSY	Plug Pin ASSY	1
5.6	GB70M6*10N19	Socket Head Cap Screw M6*10	1
5.7	GB956DN2	Flat Washer $\Phi 6.6 * \Phi 12 * 1.6$	1

# Exploded View and Parts List

## Seat Cushion Frame ASSY     Adjustable Frame II ASSY

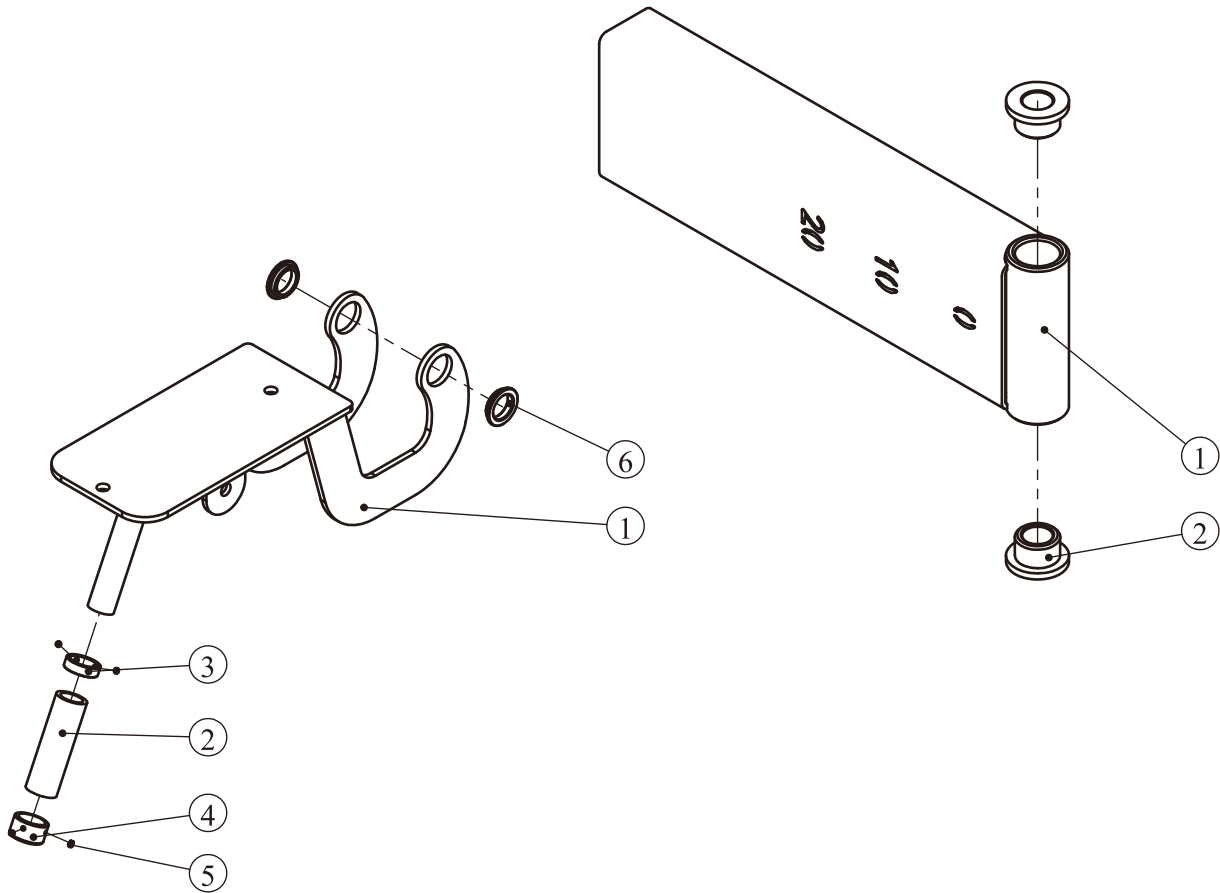

Grade No.	Part No.	Description	QTY
6.1	ITF88020600	Seat Cushion Frame	1
6.2	HSP70533100	Grip STΦ30*Φ22*120	1
6.3	V39500	Aluminum Grip Ring Φ25.4	1
6.4	V39600	Aluminum Grip Cap Φ25.4	1
6.5	YZGB7710-32*3.2N19	Socket Set Screw 10-32UNF*3.2	4
6.6	AXT3S2800	Copper Bearing	2

Grade No.	Part No.	Description	QTY
7.1	ITF88020400	Adjusttable FrameII	1
7.2	M01402000	Copper Bearing	2

# Exploded View and Parts List

## Support Frame ASSY

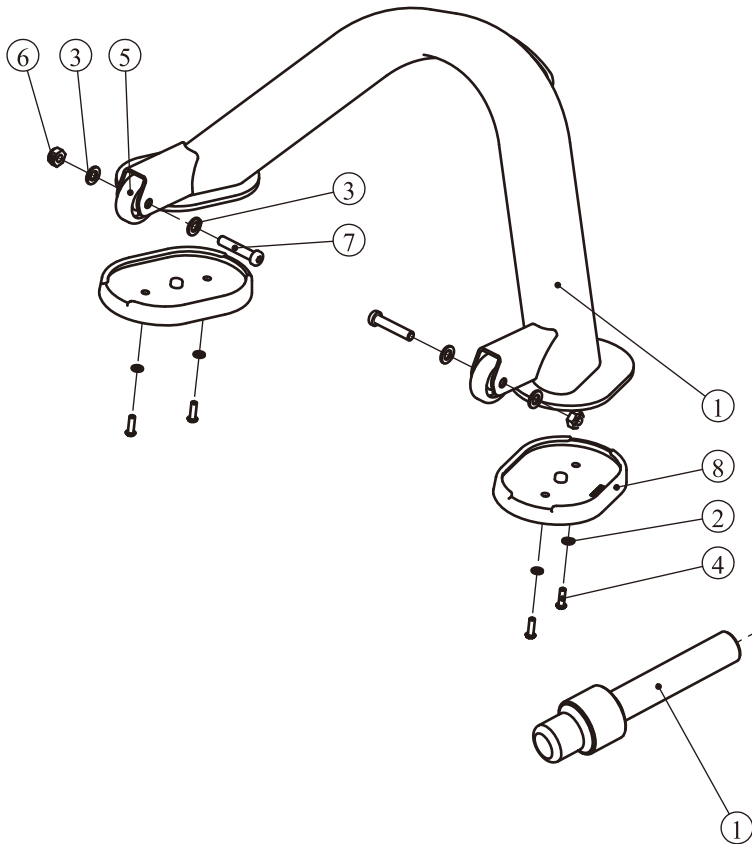

## Plug Pin ASSY

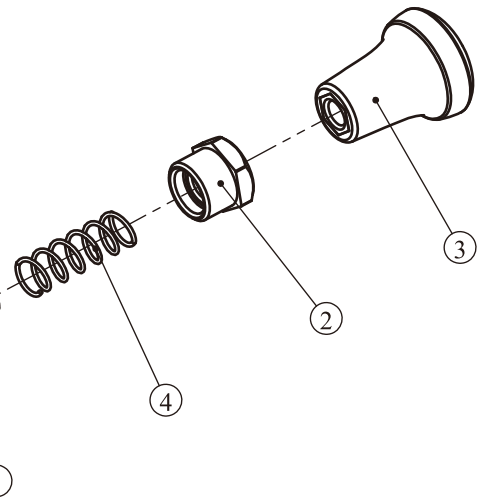

Grade No.	Part No.	Description	QTY
8.1	ITF88020800	Support Frame	1
8.2	GB956DHS2	Flat Washer $\Phi 6.6 * \Phi 12 * 1.6$	4
8.3	PNLM6*20DHS20NL	Button Head Cap Screw M6*20	4
8.4	BNH0633	Small Wheel	2
8.5	GB9510DN2	Flat Washer $\Phi 11 * \Phi 20 * 2$	4
8.6	NM10DN2	Nylon Lock Nut M10	2
8.7	GB70BTM10*50DN18	Socket Head Cap Screw M10*50	2
8.8	ITF88013200	Floor Mat	2

Grade No.	Part No.	Description	QTY
9.1	ITF88020901	Plug	1
9.2	KPS18002701V1	Locknut	1
9.3	CWRVL0052100P116C	Handle	1
9.4	HF1642303	Spring	1

# Measurement Guide

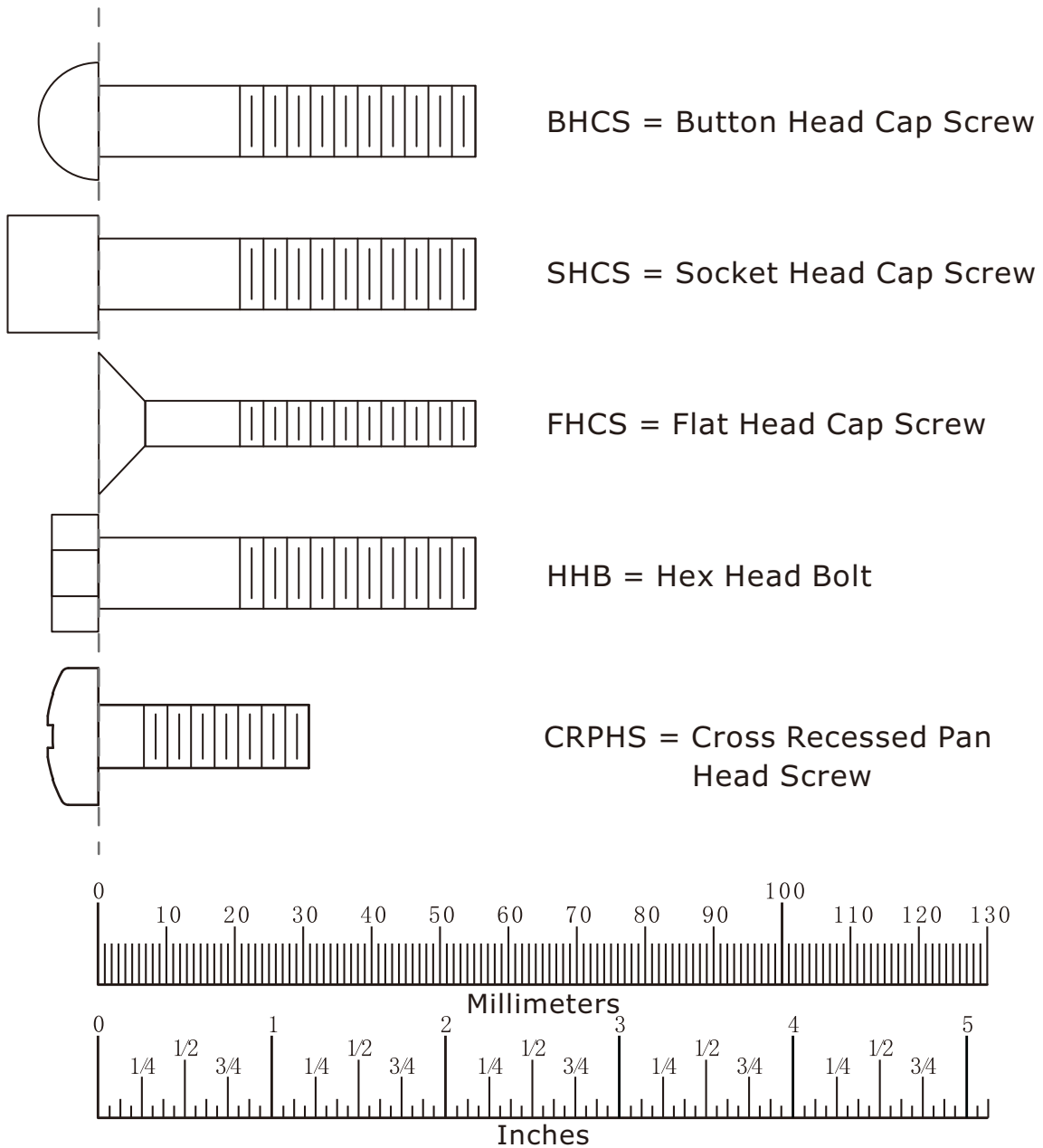

Diameter of bolt (mm/inch)	M6(1/4")	M8(5/16")	M10(3/8")	M12(1/2")	M16(5/8")
Tightening torque (N.m)	9~12	22~30	45~59	78~104	193~257
Operational methods for adult men	The strength of the wrist	The strength of the wrist and forearm	The strength of the entire arm	The strength of the arm and upper body	with all strength

# Assembly Instructions

Assembly of the equipment takes professional installers about 2 hours. If this is the first time you have assembled this type of equipment, plan to spend more time. It is strongly recommended to assemble the equipment by professional installers. You may find it quicker, safer, easier to assemble this equipment with the help of a friend, as some of components may be large, heavy or awkward to handle alone. It is important that you assemble your product in a clean, clear, uncluttered area. This will enable you to move around the product while you are fitting components and reduce the possibility of injury during assembly.

 **NOTE**

As with any assembled part, proper alignment and adjustment is critical. While tightening the fasteners, be sure to leave room for adjustments. Do not fully tighten the fasteners until instructed to do so. Be careful to assemble the components in the sequence presented in this guide.

# Assembly

## STEP 1

Attach one Plastic Connection II (#10) to Support Frame ASSY (#8), attach Underframe ASSY (#1) to Support Frame ASSY (#8), attach Sleeve Frame I ASSY (#2) and Sleeve Frame II ASSY (#5) to Underframe ASSY (#1) using:

- six Flat Washer  $\Phi 13 \times \Phi 24 \times 2.5$  (#20)
- two Spring Washer  $\Phi 12$  (#23)
- two Socket Head Cap Screw M12\*30 (#15)
- two Socket Head Cap Screw M12\*140 (#17)
- two Nylon Lock Nut M12 (#21)

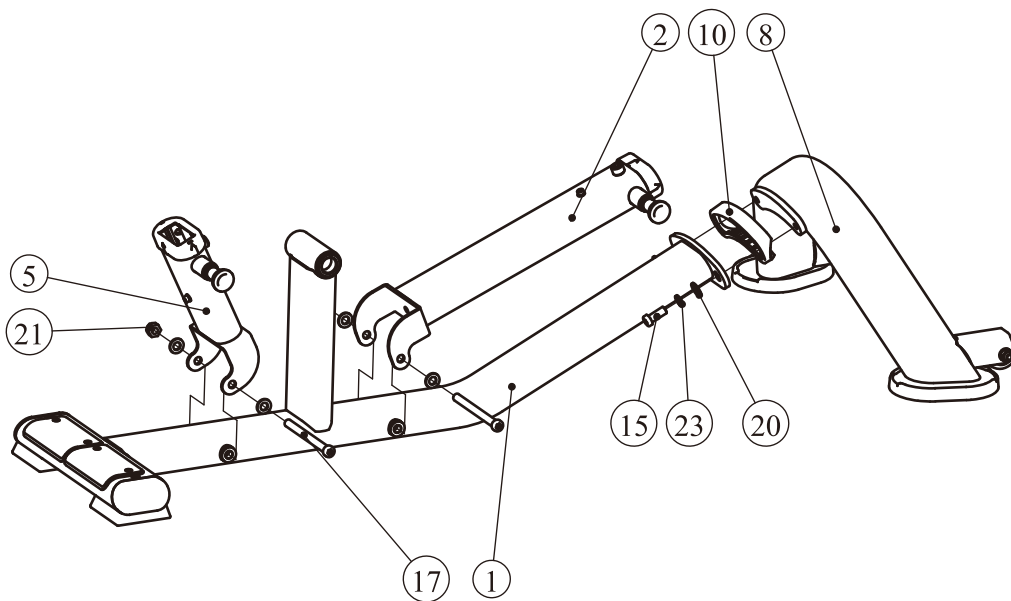

# Assembly

## STEP 2

Attach Adjustable Frame I ASSY (#4) and Adjustable Frame II ASSY (#7) to Underframe ASSY (#1) using:

two Socket Head Cap Screw M10\*35 (#14)

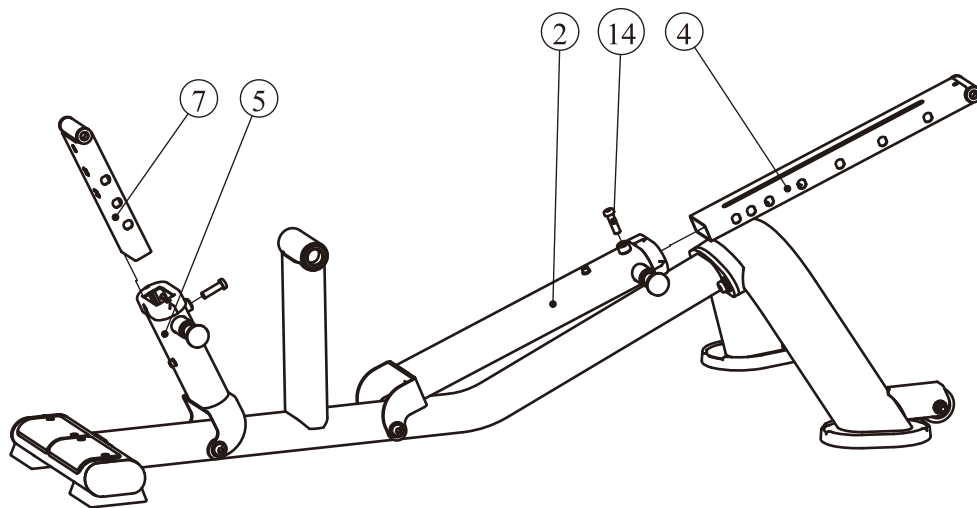

# Assembly

## STEP 3

Attach Shaft (#9), Back Support Frame ASSY (#3) and Seat Cushion Frame ASSY (#6) to Underframe ASSY (#1), connect Back Support Frame ASSY (#3) and Adjustable Frame I ASSY (#4), connect Seat Cushion Frame ASSY (#6) and Adjustable Frame II ASSY (#7), using:

one Socket Head Cap Screw M12\*160 (#18)

six Flat Washer  $\Phi 13*\Phi 24*2.5$  (#20)

three Nylon Lock Nut M12 (#21)

three Socket Head Cap Screw M12\*115 (#16)

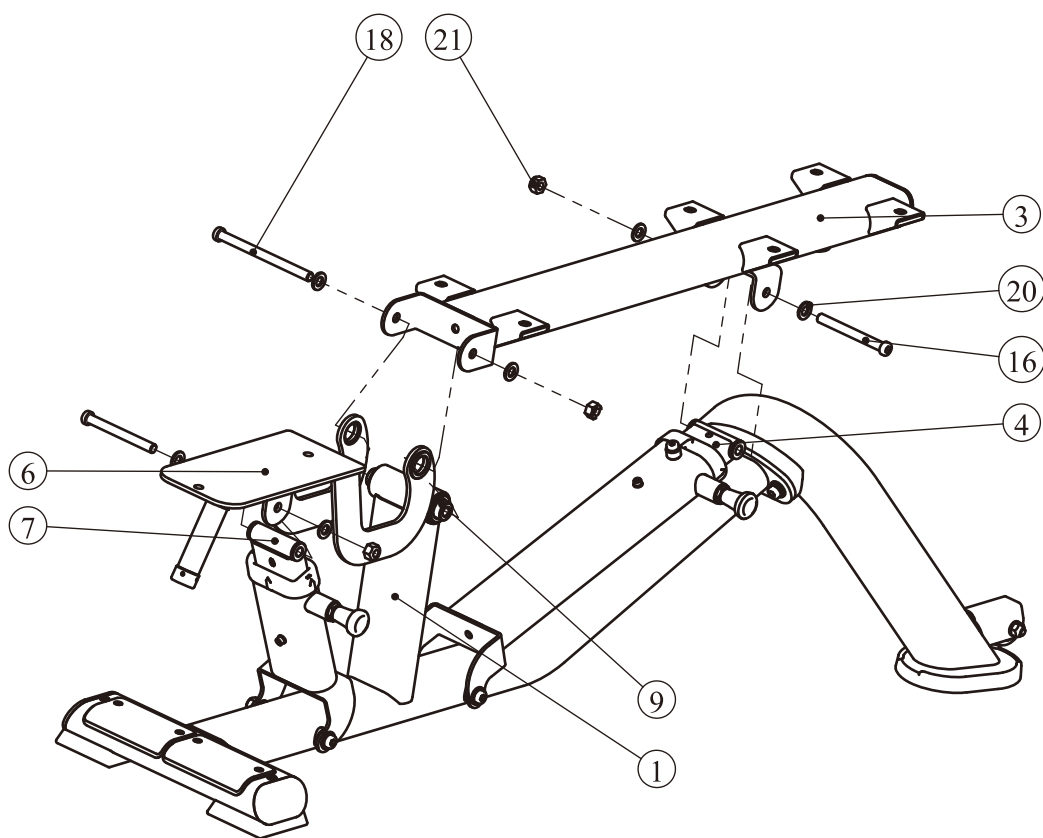

# Assembly

## STEP 4

Attach Seat Cushion (#13), Back Cushion (#11) and Head Cushion (#12) to Seat Cushion Frame ASSY (#6) and Back Support Frame ASSY (#3) using:

eight Flat Washer  $\Phi 11 * \Phi 20 * 2$  (#19)

eight Spring Washer  $\Phi 10$  (#22)

eight Socket Head Cap Screw M10\*35 (#14)

**Note: Wrench Tighten Bolts and Nylon Lock Nuts.**

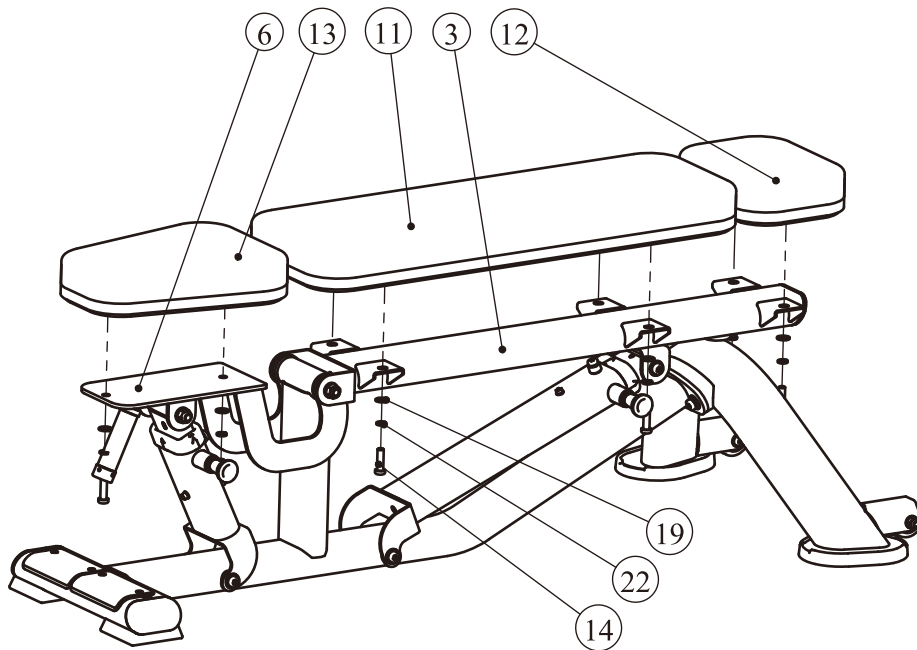

# Adjust Instructions and Exercise Instructions

## Seat Cushion adjustment

1. Pull the Pull Pin 1 and adjust Seat Cushion to desired position.
2. Make sure the Pull Pin gets into the hole completely.

## Back Cushion adjustment

1. Pull the Pull Pin 2 and adjust Back Cushion to desired position.
2. Make sure the Pull Pin gets into the hole completely.

## Exercise Instructions

1. Abdominal crunch.
2. Strength training exercises with barbell or dumbbell.

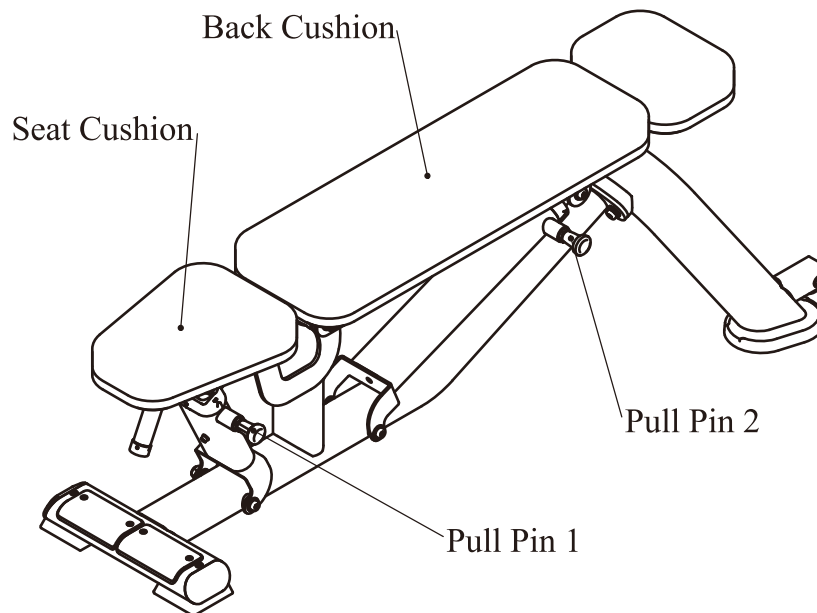

# Maintenance Schedule

ROUTINE	COMMERCIAL MAINTENANCE	HOME MAINTENANCE	LATEST DATE ENTRY					
Inspect; Links, Pull Pins, Snap Locks, Swivels, Weight Stack Pins	DAILY	WEEKLY						
Clean; Upholstery	DAILY	WEEKLY						
Inspect; Cables or Belts and their tension	DAILY	WEEKLY						
Inspect; Accessory Bars, and Handles	WEEKLY	3 MONTHS						
Inspect; All Decals	WEEKLY	3 MONTHS						
Inspect; All Nuts and Bolts, Tighten if needed	WEEKLY	3 MONTHS						
Inspect; Anti-Skid Surface	WEEKLY	3 MONTHS						
Clean & Lubricate; Guide Rods with a Teflon (PTFE) based lubricant (Superlube)	MONTHLY	3 MONTHS						
Lubricate; Seat Sleeves, Turcite Bushings, Linear Bearing	MONTHLY	3 MONTHS						
Clean and Wax; All Glossy Finishes	6 MONTHS	YEARLY						
Repack with Grease; Linear Bearings	6 MONTHS	YEARLY						
Replace; Cables, Belts and Connecting Parts	YEARLY	3 YEARS						

*Your equipment comes with a commercial maintenance decal. For personal, in home use, please follow the home maintenance schedule listed above.*

# General Maintenance Information

## **Links, Pull-Pins, Snap Hooks, Swivels, Weight Stack Pins:**

- \* Check all pieces for signs of visible wear or damage.
- \* Check springs in snap hooks and pull-pins for proper tension and alignment.
- \* If the spring sticks or has lost its rigidity, replace it immediately.

## **Upholstery:**

- \* To ensure prolonged upholstery life and proper hygiene, all upholstered pads should be wiped down with a damp cloth after every workout.
- \* Periodically take the time to use a mild soap or an approved vinyl upholstery cleaner to deter the onset of cracking or drying. Avoid using any abrasive cleaners or cleaners not intended for use on vinyl.
- \* Replace ripped or worn upholstery immediately.
- \* Keep sharp or pointed objects clear of all upholstery.

## **Decals:**

- \* Inspect and familiarize yourself with any safety warnings or other user information posted on each decal.

## **Nuts and Bolts:**

- \* Inspect all nuts and bolts for any loosening and tighten if needed.
- \* Go through a re-tightening sequence periodically to ensure that all hardware is tensioned proper.

## **Anti-Skid Surfaces:**

- \* These surfaces are designed to supply secure footing and need to be replaced if they appear worn or become slippery.

## **Belts and Cables:**

- \* We use only high quality belt, and mil-spec cables.
- \* Visually inspect the belts and cables for fraying, cracking, peeling or discoloration.
- \* While the machine is not in use, carefully run your fingers along the belt or cable to feel for thinning or bulging areas.
- \* Replace belts and cables immediately at the first signs of damage or wear. Do not use equipment until belts or cables have been replaced.

## **Belt and Cable Tension:**

- \* Referring to the Owners Manual, when belts or cables are used check all bolts attachments to be sure they are properly attached.
- \* Check slack in cables and re-adjust cable tension if needed.

## **Seat Sleeves, Guide Rods:**

- \* Wipe down adjusting tubes with a dust free rag before applying lubricant.
- \* Lubricate seat sleeves and Guide Rods with a Silicon or Teflon based lubricant spray.

## **Linear Bearings:**

- \* Referring to the Owners Manual carefully disassemble the bearing from its housing and place a finger full of light grease (lithium, super lube, etc.) into the inside of the bearing. Using your finger, press the grease into the ball-bearings and their tracks. Repeat until the ball-bearing tracks are full of grease. Insert the shaft back into the bearing and wipe off excess grease.

**PLEASE KEEP THIS FOR YOUR RECORDS**

# Weight Training Tips

Use this manual to guide you through the basic exercises you can perform on your equipment. To gain maximum results and avoid possible injury, consult a fitness professional to develop your complete exercise program.

Always consult your physician before starting any exercise program.

To be successful in your exercise program, it is important to develop an understanding of the basic principles of strength training. Now that you have your equipment, it is only natural that you want to get started immediately. First, determine a set of realistic goals and objectives for yourself. By deciding on an exercise plan that is right for you prior to starting, you will contribute significantly to your success.

Warm up properly before engaging in weight resistance training. Stretching, yoga, jogging, calisthenics or other cardiovascular exercise can help prepare your body for the heavier workload of lifting weights.

Learn how to perform the exercise correctly before using heavy weight. Correct form is important to avoid injury and to ensure that you work the proper muscle groups.

Know your limitations. If you are new to weight training or are embarking on an exercise regimen after a long layoff, start slowly and build foundational strength over a longer period of time.

Pay attention to your breathing. Exhale when you exert is a general rule of thumb. Never hold your breath.

